

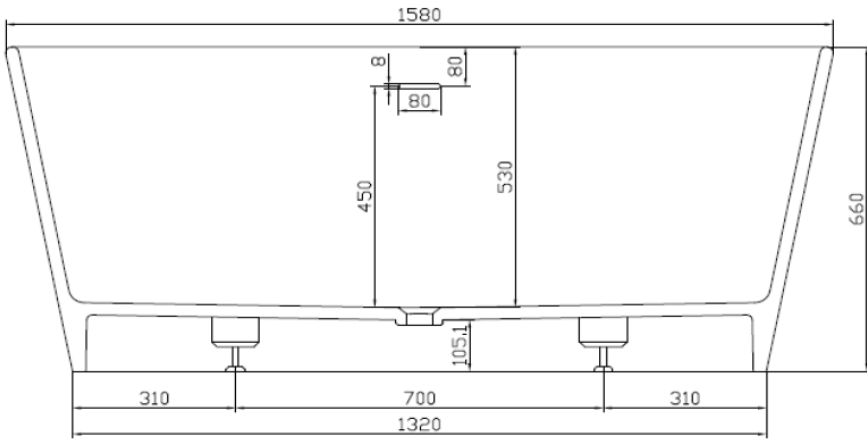

SOLIDGLAM PS IDV 278607

SOLID SURFACE ELONGATED BATHTUB

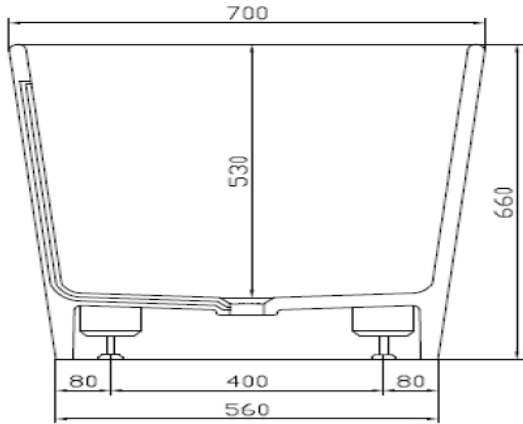
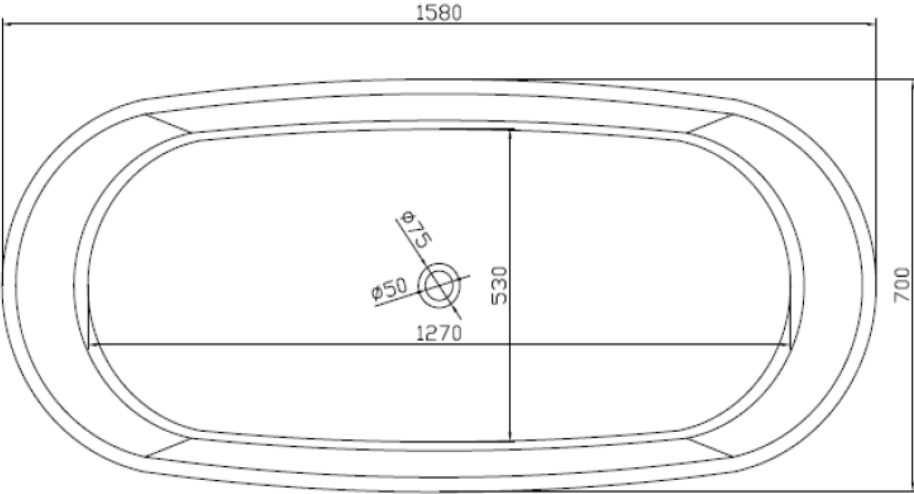

SOLIDGLAM PS IDV 278607
62"x 28"x 26" / 158x 70x 66cm
NET WEIGHT 287 LBS / 129 KGS - WATER CAPACITY 87 G. / 330 L
OVER FLOW HOLE W. SOLID MATTE WHITE POP-UP & DRAINAGE.
EDGE THICKNESS: 1"
ADJUSTABLE FEET.



Project Information
Job Name: _____ Date: _____ Type of hardware: _____
Comments: _____
Approved: _____